



AC/TRMS Voltage Hawk™ HK35 & HK45 Series Advanced Digital Panel Meter

- Easily Programmed from the Front Panel
- Software Functions Include:
 - Password
 - One or Two Set Points
 - Time Delay & Hysteresis
 - Display Scaling
 - Decimal Point Selection
- 3-1/2 or 4-1/2 Digit, Bright Red 0.56" (14.2 mm) Display
- Removable Screw Terminal Connector for Easy Installation
- 1/8 DIN Case, Made of High-Impact Noryl®
- Five AC/AC TRMS Voltage Ranges: 200mV, 2V, 20V, 200V, 750V
- Display Hold
- Optional 5-Amp Relays and Analog/Digital Outputs



Simpson's Hawk advanced digital panel meters are ideal for measuring and controlling a wide variety of process variables. The display can be easily scaled from the front panel to virtually any engineering unit.

Two optional 5-amp relays include front panel programming features for hysteresis, time delay and relay operation. Optional analog or digital outputs are available for use with chart recorders or computers. Other programmable software features include programmable decimal point and a password lockout feature.

By using the password feature, the meter's programming functions and set points are protected from accidental re-programming.

Hawk series advanced digital panel meters are compactly designed for applications requiring minimal rear panel depth and feature a standard 1/8 DIN case made of high-impact Noryl®. The Hawk has an optional NEMA 4-rated front panel cover that equips the unit for wash-down environments. A two-piece screw terminal is standard for easy installation and removal of the meter.

Installation and Panel Cutout

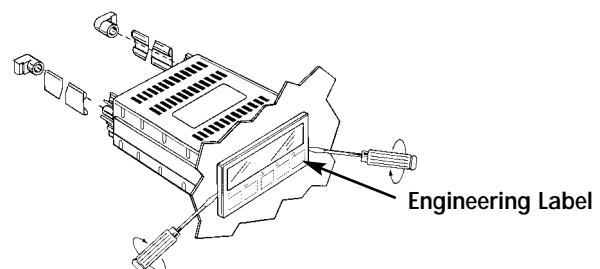
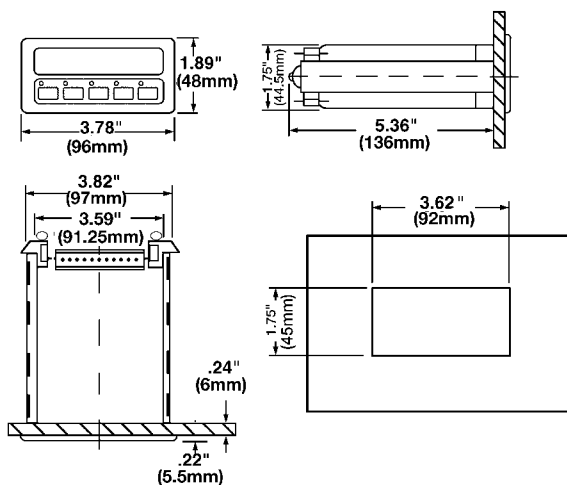

Mounting Requirements

Insert the instrument into the panel and fasten it with the mounting brackets and side retainers provided.

Engineering Label Placement

To replace the engineering unit label, insert a screwdriver into the lateral slot in the front panel and gently twist the screwdriver. Remove the front panel completely, and replace the engineering unit label with tweezers. Snap the front panel on after label is replaced.

Specifications

DISPLAY

Type: 7-segment, red LED

Height: 0.56" (14.2mm)

Decimal Point: 3 or 4-position software programmable from front panel

Overrange: Display (flashing) indicates maximum reading (Hi)

Underrange: Display (flashing) indicates minimum reading (Lo)

Alarm Indicators: 2 LED indicators

POWER REQUIREMENTS

AC Voltages: 24, 48, 110, 220VAC, ±15%

DC Voltages: 9-32VDC (max. 3.5amp draw on start-up)

Power Consumption: 9VA

ACCURACY @ 25° C

AC:

HK35: 0.3% of input ±2 digit

HK45: 0.2% of input ±2 digit

AC TRMS:

±(0.2% of input ±2 digit) for crest factor ≤2 and frequency from 40 to 1KHz

AC TRMS cont.:

±(0.4% of input ±5 digits) for crest factor ≤3 and frequency from 40HZ to 1KHZ

±(0.7% of input ±5 digits) for crest factor ≤6 and frequency from 40Hz to 1 KHz

ENVIRONMENTAL

Operating Temp.: 0°C to +50 °C

Storage Temp.: -10 °C to +60 °C

Relative Humidity: <90% non-condensing

Ambient Temperature: 25°C

Temperature Coefficient (per °C):

AC: ±150PPM/°C

Warmup Time: 15 minutes

NOISE REJECTION

NMR: 60dB @ 50/60Hz

CMRR: 70dB (1 KΩ unbalance) @ 50/60Hz

ANALOG TO DIGITAL CONVERSION

Technique: Special dual slope

RATE

HK35: 4 times-per-second

HK45: 2 times-per-second

MECHANICAL

Bezel: 3.79" x 1.89" x 0.22"
(96mm x 48mm x 5.5 mm)

Depth: 5.35" (136mm)

Panel Cutout: 3.6" x 1.8" (92mm x 45mm)

Case Materials: 94 V-1 UL rated Noryl®

Weight: 16oz (453.6g)

INPUTS: AC/AC TRMS Voltage

Input Range	Display Resolution		Max. Overload	Input Impedance
	HK35	HK35		
200mV	100µV	10µV	50V	1MΩ
2V	1mV	100µV	100V	100KΩ
20V	10mV	1mV	100V	1MΩ
200V	100mV	10mV	750V	1MΩ
750V	1V	100mV	750V	1MΩ

Wiring Diagram

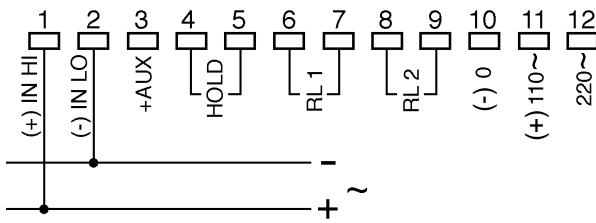

Input Signal:

Connect the input signal to the IN HI and the IN LO terminals(#1 and #2).

Supply Power:

110VAC & 24VAC are connected to terminals #10 and #11.

220VAC & 48VAC are connected to terminals #10 and #12.

9-32VDC is connected to terminals #10(-) and #11(+).

Display Hold: This is a standard feature on the Hawk controller. The display value can be held indefinitely by shorting terminals #4 and #5. The comparison of the input variable with the alarm set point remains active. This allows the controller to function normally when the display is held (allowing a reading to be taken). To reactivate the display, remove the short between the two terminals.

Programming

The Hawk ships with either Standard Programming or Quick Set Point Access Programming. Programming commands are identical for both formats, but the Quick Set Point Access units allow the user to change the set points without entering the programming mode, thereby preventing possible mis-entry of other parameters.

If your unit is a Quick Set Point Access unit, the first parameters shown will be the set points. These can be changed without entering a password. If your unit has Standard Programming, the first parameter will be the password, which must be entered before further parameter access is allowed.

The Programming mode allows the user to define the following instrument parameters:

- Alarm set point values (if a quick set point access unit)
- Password for access to programming
- Decimal point position
- Minimum and maximum values of the electrical range
- Display scaling
- Alarm set point values (for all units)

The normal measurement and control functions are not active during programming mode. **The input variable is not monitored during the programming sequence.**

Quick Set Point Access Programming Parameters and Values

Parameter	Value
SP (1)	100*
SP (2)	200*
PAS	0
D.P.	Per Specification
LoE	Per Specification
HiE	Per Specification
Lo	Per Specification
Hi	Per Specification
SP (1)	100
uP/do	uP
hYS	0
dEL	0
nd/nE	nd
SP (2)	200
uP/do	uP
hYS	0
dEL	0
nd/nE	ne

Standard Programming Parameters and Values

Parameter	Value
PAS	0
D.P.	Per Specification
LoE	Per Specification
HiE	Per Specification
Lo	Per Specification
Hi	Per Specification
SP (1)	100
uP/do	uP
hYS	0
dEL	0
nd/nE	nd
SP (2)	200
uP/do	uP
hYS	0
dEL	0
nd/nE	ne

programming sequence. The operator can exit the programming mode at any time by pressing the **S** key. Termination for the programming mode is automatic after the last variable is entered. The Hawk will return to the measurement and control mode after the programming mode is exited or if 45 seconds has passed between pressing keys.

In this section, the programming references the 3-1/2 digit unit. If you are using a 4-1/2 digit unit, simply add another digit to the references made herein. During the programming sequence, the "PV" LED will flash to indicate you are in the programming mode. The programming mode can be exited at any time by pressing the **S** key.

Programming (Cont'd)

Programming the Set Points (for quick set point access units only)

The Hawk is shipped with two programmable set points for the alarm LEDs on the front panel. Optional relays can be added to the unit, and will work based on the parameters programmed to the set points. These relays can be used to turn on a light or process. The set point is relative to the span (defined by "Lo" and "Hi"), not the electrical input range. The set points can be displayed during normal operation by pressing the ▲ or ▼ key. The "SP1" LED will turn on, and the display will show set point #1. Press the ▲ key again, "SP1" will turn off, "SP2" will turn on and set point #2 will be displayed. The display will stay on for ten seconds, then revert to normal operation.

Alarm Set Point #1 (SP)

The display will show "SP" for one second. The "SP1" LED will flash while you are programming the "SP1" values, and the "PV" LED will stop flashing. The stored set point value is displayed, and can be changed up or down by using the ▲ or ▼ key. Press **ENTER** to lock in the value and to pass to programming access (PAS).

Access to Programming (PAS)

Press the **S** key. The display will show "PAS" for about one second. The ▲ and ▼ keys affect the displayed value up or down. The correct password must be displayed, then press the **ENTER** key. The unit is shipped with a password of "0."

Programming a new password

If the correct password is entered, the "PV", "SP1", and "SP2" LEDs will flash. The display will show "PAS" for one second, and then the password will be displayed again.

To retain the password, press **ENTER** to pass to the next parameter. To change the password, press the ▲ or ▼ keys until the desired password is displayed. Then press the **ENTER** key to proceed to the next parameter.

Decimal Point Selection (dP)

The display will show **dP** for one second. The display will then show "1111" and the "PV" LED will be flashing. The current decimal point position will be displayed. To change to position of the decimal point, press the ▲ or ▼ key to move it left or right, respectively. Press the **ENTER** key to pass to the next parameter.

Electrical Input Range (LoE and HiE)

The input range must be specified. The display will indicate "LoE" (low electrical input) for one second, then the stored value will be displayed.

To retain the stored value, press **ENTER**. To increase or decrease the "LoE", press the ▲ or ▼ key until the desired value is displayed. Generally, "LoE" is set for 0.00. Press **ENTER** to lock in the "LoE" value.

"HiE" (high electrical input) will appear for one second, then the stored value will be displayed. To retain this value, press **ENTER**. To modify the "HiE" value, use the ▲ and ▼ keys. If you are using a 100 AC volta unit, set the HiE at 100.0 (ACV). Press **ENTER** to lock in the new value.

Display Scaling (Lo/Hi)

The display can be scaled to any engineering unit. This allows the unit to easily display values from portable or switchboard shunts. Following our previous example:

Electrical Input Range : 0 to 100.0 ACV (LoE to HiE)

Programmed Display Scaling: 0.0 to 50.0 psi (Lo to Hi)

The link between the input value and the displayed value is completely adjustable. Thus, it is possible to correlate a minimum input value to a maximum displayed value. This is called "scale inversion."

The display will show "Lo" for one second. This is the minimum displayed value corresponding to the input range. The stored value will be displayed. In our example, the value is 0.0 (ACV). To retain the stored value, press **ENTER**. To modify the value, use the ▲ and ▼ keys to increase or decrease the value. Press **ENTER** to lock in this new value and pass to the next parameter.

The Display will show "Hi" for one second, then the stored value will be displayed. This value can be changed up or down by using the ▲ and ▼ keys. By changing the high value, the input is scaled to display a new range. In our example, when our process is using 100 volts, the system is generating 50psi. The value is 50.0 (psi). Press **ENTER** to pass to the next parameter.

(Set Point Programming Continued)

In quick set point access units, set point values are entered at the beginning of the programming sequence. The remaining set point parameters are programmed behind the password protection. In all units, the next four prompts relate to SP1, and will then be repeated for SP2. For standard units, follow the "Programming the Set Points" at the beginning of this programming section before continuing.

High and Low Alarm Level (uP/do)

The display will indicate "uP" or "do" signifying high or low alarm level. Use the ▲ and ▼ keys to change the state. Press the **ENTER** key to pass to the next parameter.

Hysteresis (HYS)

"HYS" will be displayed for one second. Hysteresis is the difference between the set point value (at which the alarm is enabled) and the value at which you want to disable the alarm.

Hysteresis is selectable from 0% to 100.0% of the maximum display span. Use the ▲ and ▼ keys to affect the value displayed, and press **ENTER** to lock in the new Hysteresis value.

Time Delay (dEL)

The Time Delay is programmable for 0 to 99 seconds. Time delay differs from Hysteresis, because this value indicates how long the Hawk will wait after reaching an alarm state before turning on the "AL1" LED (and triggering the relays, if installed).

The Hawk will display "dEL" for one second, and then display the stored value. To change the value, use the ▲ and ▼ keys to increase or decrease the value. Press **ENTER** to store the new value in memory.

Relay Status (nd/nE)

This is the relay status in the absence of an alarm condition. The instrument will display the stored value, which can be changed by pressing the ▲ or ▼ key. ▲ will make the status Normally Energized ("nE"), while the ▼ key will make the status Normally De-energized ("nd"). Press **ENTER** to select the desired setting.

Set Point #2

If the unit is equipped with two relays, the programming sequence will continue. The "SP1" LED will turn off, the "SP2" LED will turn on, and the Hawk will proceed through the programming sequence for the second set point.

Exiting Programming Mode

After programming the relay(s), the Hawk will automatically exit the programming mode. The "SP1" LED (or "SP2" if you have two relays) is turned off, and the "PV" LED will start flashing. The display will show "run" for about one second, then the unit will function normally. The programming mode can be exited at any time by pressing the **S** key.

Removable Connector

A special two-piece removable connector is standard on the Hawk controller. This allows the unit to be removed from the wiring connections easily without the need to disconnect the signal input wires.

Attach the input signal and power supply to the screw terminal connector provided with the unit.

The screw terminal connector is attached to the mating connector on the back of the Hawk unit (see the diagram). Extra connectors are available at your Hawk authorized distributor.

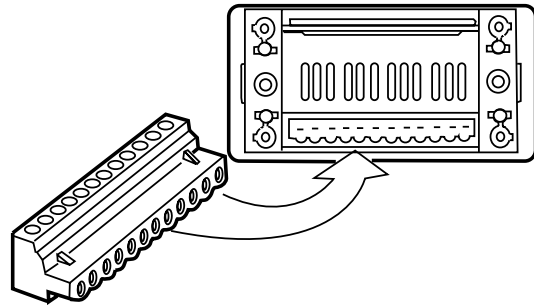

Digital Outputs

There are four digital outputs available for the Hawk:

- 1) RS422 (serial)
- 2) BCD Open Collector (parallel)
- 3) BCD Open Collector w/selection lines (parallel)
- 4) BCD Tri-State output (parallel)

Serial Outputs

The RS422 is a serial interface suitable for connecting the Hawk to personal computers, host computers or printers. The communications mode is asynchronous and mono-directional. This means that it is not possible to change the programming parameters of the Hawk directly from the computer. The data exchanged between the Hawk and the computer complies with ASCII standards. The RS422 connection must use a nine-wire shielded cable. Maximum length is 3937ft (1200m). These connections are made to the upper connector on the rear of the Hawk. See the charts below for the pin connection call-outs, and the diagram after the charts for the terminal locations on the rear of the Hawk.

Specifications:

Baud Rate: 1200, 4800, 9600, 19200.

Format:

Data Bits: 7 or 8

Parity: Even, odd or none

Stop Bits: 1 or 2

RS 422

Hawk I/O	Hawk-Computer connections	Computer I/O
Pin 1A CTS+	<-----	*
Pin 2A RTS+	----->	*
Pin 3A TX+	----->	RX+
Pin 4A RX+	<-----	TX+
Pin 1B CTS-	<-----	*
Pin 2B RTS-	----->	*
Pin 3B TX-	----->	RX-
Pin 4B RX-	<-----	TX-
Pin 5B SG	<----->	SG

Inputs

Min. Logic Levels	Max. Logic Levels
$0 \geq + 0.2V$ (diff)	$0 \leq + 12V$ (diff)
$1 \leq - 0.2V$ (diff)	$1 \geq - 12V$ (diff)

Termination Resistances : $100\Omega \pm 10\%$

Outputs

Min. Logic Levels	Max. Logic Levels
$0 \geq + 1.5V$ (diff)	$0 \leq + 5V$ (diff)
$1 \leq - 1.5V$ (diff)	$1 \geq - 5V$ (diff)

*Control lines managed by the software, to enable the correct reception of the data transmitted from the Hawk.

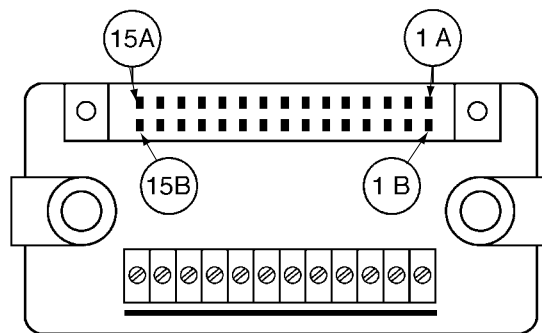

CTS = Clear to send (computer ready to receive data)

RTS = Request to send (Hawk ready to transmit data)

TX = Transmit data (data transmission from Hawk)

RX = Receive data (data reception from computer)

SG = Signal ground

Note: The inactive lines are in the high logical status. All inputs/outputs are protected from short circuits. The serial output is isolated from the input variable signal (500VRMS) by means of optocouplers.

BCD Outputs

There are three kinds of BCD outputs available for the Hawk. On the

Digital Outputs (Cont'd)

three variants, the signal outputs are protected from short circuits and isolated from the input variable signal (500VRMS) by means of optocouplers.

BCD Open Collector output signal

The connections for this output signal are to rows A and B of the upper-rear edge connector on the Hawk. All outputs are open collector types, and the voltage level relating to 0 is ≤ 1.2 volts. The power supply for open collector outputs is applied to pin 13A. It can vary from 7.5VDC to 30VDC. With this function, it is possible to use the internal supply voltage (14VDC) by placing a jumper across pin 12A with pin 13A. This voltage will not be stabilized, and it can drop to 7.5VDC. See the chart below for the appropriate pin call-outs, and the diagram below the chart for the resistance values of the external power supply and signal outputs.

Auxiliary Signals

Function	Pin	
Burn-Out	6A	
Overrange	7A	
Sign*	8A	*Negative = logical status 1
Underrange	9A	Positive = logical status 0
Ground	10A	
Internal Power supply V+	12A	
Ext. Open Coll.		
Pow. Supply V+	13A	

I_{OFF}(Max) = 250 μ A @45°C

I_{ON} (Max) = 10mA

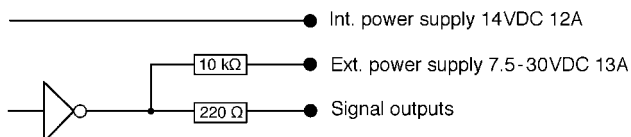

Digital Signal Outputs

1st digit(lsd)		2nd digit		3rd digit		4th digit		5th digit(msd)	
Value	Pin	Value	Pin	Value	Pin	Value	Pin	Value	Pin
1	1B	10	1A	100	5B	1,000	9B	*10,000	5A
2	2B	20	2A	200	6B	*2,000	10B		
4	3B	40	3A	400	7B	*4,000	11B		
8	4B	80	4A	800	8B	*8,000	12B		

* These signals are present only in the HK45.

BCD Open Collector w/Selection Lines

This output is very similar to the other BCD Open Collector output except for the Enable commands. The digital signal output chart does not change, but the auxiliary signals chart changes as follows:

Auxiliary Signals

Function	Pin	
Burn-Out	6 A	
Overrange	7 A	
Sign*	8 A	*Negative = logical status 1
Underrange	9 A	Positive = logical status 0
Ground	10A	
Internal Power supply V+	12A	
Ext. Open Coll. Pow. Supply	13A	
Enable 1	13B	
Enable 2	14B	
Enable 3	15B	

The power supply is connected the same way, with the same features. In addition, the digital signal outputs chart is exactly the same as the first BCD option. The only real changes are the addition of Enable commands.

The Enable commands (active low) allow you to select the group of data outputs indicated in the digital signal output table below.

Command	Data Group
Enable 1	Digit 1 and 2
Enable 2	Digit 3 and 4
Enable 3	Burn-Out, Under/Overrange, Sign, 5th digit*
	*Only for the HK 45

It is possible

to reduce the number of lines of the parallel bus from 19 (for HK35) or 23 (for HK45) to 13. This is done by connecting (in parallel) the outputs of Digit 1 and 2 with the outputs of Digit 3 and 4, and with the outputs of Burn-Out, Underrange, Overrange and Sign (and the 5th digit if you are using a HK45). Each data group can be selected by means of three Enable lines and the ground line. It is possible to use all output lines (without data group selection) by connecting the three Enable commands to ground.

It is also possible to connect more than one instrument to an acquisition unit by means of a common bus. The connection between instrument and acquisition logic must be carried out by means of a shielded cable. Maximum length 16ft (5m), maximum capacity 100pF/m).

BCD Tri-State Output Signal

Like the other BCD options, the output signals are connected to the upper rear connector on the Hawk. The main difference is that these outputs are CMOS type outputs. The voltage level relating to 0 is $\leq 1V$; relating to 1 $\geq 3.5V$. The digital signal outputs are connected to the same terminals as the other two types of BCD outputs (see the chart to the left).

Auxiliary Signals

Function	Pin	
Burn Out	6A	
Overrange	7A	
Sign*	8A	*Negative = logical status 1
Underrange	9A	Positive = logical status 0
Ground	10A	
Enable 1	13B	
Enable 2	14B	
Enable 3	15B	

The Enable commands (active low) allow you to select the group of data outputs indicated in the digital signal output table below.

It is possible to reduce the number of lines of the parallel bus for the BCD Tri-State outputs. This is done in the same manner as the BCD Open Collector w/ Selection Lines output signal.

Command	Data Group
Enable 1	Digit 1 and 2
Enable 2	Digit 3 and 4
Enable 3	Burn-Out, Under/Overrange, Sign, 5th digit*
	*Only for the HK 45

It is also possible to connect more than one instrument to an acquisition unit by means of a common bus. The connection between instrument and acquisition logic must be carried out by means of a shielded cable. Maximum length 16ft (5m), maximum capacity 100pF/m).

For information on connecting the Hawk to a printer or host computer, please call the factory. We have additional information we can fax or mail to you upon request.

Analog Outputs

There are five different analog output signals available in the Hawk:

- 1) 4-20mADC
- 2) 0-1VDC
- 3) 0-10VDC
- 4) 1mVDC / digit (HK35 & HK45 TC/RTD)
- 5) 0.1mVDC / digit (HK45 except TC/RTD)

The analog outputs are protected from short circuits (except the 4-20 mA). All of the connections referenced on the following chart are for the upper edge connector on the rear of the Hawk controller. Please note that pin 1A is on the extreme right and 15A is on the extreme left. Also, when a Burn-Out, Overrange or Underrange condition occurs (on the outputs relating to 6A, 7A, or 9A), a signal of 5 VDC is available. If none of these conditions occur, the signal is 0VDC (typical values).

The following table shows the logic outputs for all the Analog Output variations.

Pin #	Logic Output
6A	Burn-Out (only for TC/RTD)
7A	Overrange
8A	Sign (steady at 0)
9A	Underrange
10A	Ground

The following table indicates the terminal points where the output signal emanates from.

Analog Output	Out +	Out -
4-20mADC	Pin 13A	Pin 14A
0-1VDC	Pin 12A	Pin 11A
0-10VDC	Pin 12A	Pin 11A
1mVDC/digit	Pin 12A	Pin 11A
0.1mVDC/digit	Pin 12A	Pin 11A

The diagram to the right shows the upper and lower terminals for connections.

The following tables show the relationship between the output signal and the displayed value.

4-20mADC:

$$I = (16/Hi-Lo) \times (RDG-Lo) + 4$$

I = Output current (mA)

Hi = Max. display value of the whole measuring range

Lo = Min. display value of the whole measuring range

RDG = Displayed value

Accuracy: $\pm 0.25\%$ of input $\pm 0.01\text{mA}$ @25°C

Temperature Drift: $\pm 120\text{PPM}/^\circ\text{C}$

Max. Load Resistance: 400Ω

Max. Output Current @5V: $\leq 0.7\text{mA}$ (Output $\geq 3.9\text{V}$) Outputs 6A, 7A, 9A.

Max. Output Current @0V: $\leq 0.7\text{mA}$ (Output $\leq 0.8\text{V}$) Outputs 6A, 7A, 9A.

Type of Isolation: By means of optocouplers

Isolation Voltage: 500Vrms (between input and output)

0-1 VDC and 0-10 VDC:

$$V = (RDG - Lo) / (Hi - Lo)$$

V = Output voltage (V)

Hi = Max. display value of the whole measuring range

Lo = Min. display value of the whole measuring range

RDG = Displayed value

Accuracy: $\pm 0.20\%$ of input $\pm 0.01\text{V}$ @25°C

Temperature Drift: $\pm 80\text{PPM}/^\circ\text{C}$

Min. Load Resistance: 10 KΩ Output Resistance: $\leq 3\Omega$

Max. Output Current @5V: $\leq 0.7\text{mA}$ (Output $\geq 3.9\text{V}$) Outputs 6A, 7A, 9A.

Max. Output Current @0V: $\leq 0.7\text{mA}$ (Output $\leq 0.8\text{V}$) Outputs 6A, 7A, 9A.

Type of Isolation: By means of optocouplers

Isolation Voltage: 500V rms (between INPUT and OUTPUT)

1 mVDC / digit:

$$\text{mV} = \text{RDG} \times (\text{number of digits})$$

mV = Output voltage (mV)

RDG = Displayed value

For example, if the displayed value corresponds to 100.0%, the output voltage is 1000mV (1V).

Accuracy: $\pm 0.20\%$ of input $\pm 0.01\text{V}$ @25°C

Temperature Drift: $\pm 80\text{PPM}/^\circ\text{C}$ (HK 35), $\pm 120\text{PPM}/^\circ\text{C}$ (HK45 TC/RTD)

Min. Load Resistance: 10KΩ

Max. Output Current @5V: $\leq 0.7\text{mA}$ (Output $\geq 3.9\text{V}$) Outputs 6A, 7A, 9A.

Max. Output Current @0V: $\leq 0.7\text{mA}$ (Output $\leq 0.8\text{V}$) Outputs 6A, 7A, 9A.

Type of Isolation: By means of optocouplers

Isolation Voltage: 500Vrms (between input and output)

0.1 mVDC / digit:

$$\text{mV} = (\text{RDG} / 10) \times (\text{number of digits})$$

mV = Output voltage (mV)

RDG = Displayed value

Accuracy: $\pm 0.20\%$ of input $\pm 0.001\text{V}$ @25°C

Temperature Drift: $\pm 80\text{PPM}/^\circ\text{C}$

Min. Load Resistance: 10 KΩ Isolation Voltage: 500V rms

Max. Output Current @5V: $\leq 0.7\text{mA}$ (Output $\geq 3.9\text{V}$) Outputs 6A, 7A, 9A.

Max. Output Current @0V: $\leq 0.7\text{mA}$ (Output $\leq 0.8\text{V}$) Outputs 6A, 7A, 9A.

Type of Isolation: By means of optocouplers

Resolution: 12 Bit Output Resistance $\leq 3\Omega$

Isolation Voltage: 500Vrms (between input and output)

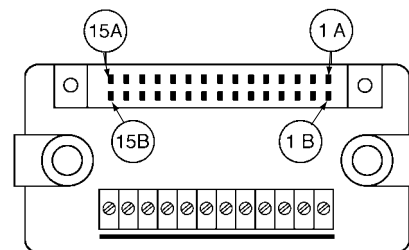

Engineer's Notes

Relays

Optional relays are available with the Hawk. The relays are 5-amp, 250VAC, DPST models. Up to two relays can be installed in the Hawk controller. The relays are programmed through the software in the Hawk to be normally energized or normally de-energized, and are activated (or de-activated) based on the set points. Hysteresis for the relays is easily programmed in the Hawk to eliminate "chatter" in the relays. The Hawk has a time delay adjustment of 0 to 99 seconds for the set points.

The relays are set up during the programming sequence. The values for the alarm levels correspond to the set point values. When an alarm condition is met, the relay will be enabled (or disabled) and the appropriate alarm light (AL1 or AL2) will flash. This gives the operator a visual indication that the relay has been enabled (or disabled).

Relays can be used to "turn on" or "turn off" power to a process that the Hawk is monitoring. A light can be "turned on" when a set point is exceeded, alerting the operator to a change in condition in the process. Also, the excitation or analog output of the Hawk can be controlled with the relays by wiring them together, "turning on" or "turning off" the output when a set point is reached or exceeded.

Note:

The unit is delivered with normally closed contacts (NC) for the alarm relays. If you would prefer the contacts to be normally open, that must be specified (NO) when the order is placed.

By changing the values of the alarm status and the relay status, the controller will act as though the contacts had been changed, without actually changing them.

The chart shows the alarm and relay conditions when the configuration is changed.

RELAY SPECIFICATIONS

Breakdown Voltage: 750VRMS (60Hz) across contact gap, 4,000VRMS (60Hz) between coil and contacts

EXPECTED LIFE

Mechanical: 20 million operations minimum
 Electrical: 100,000 operations minimum
 Temperature range: -40°C to 70°C

TIME VALUES

Pull in time: 8mS maximum
 Drop out time: 4mS maximum

CONTACTS

Ratings: 5A @ 250VAC
 Material: Ag - Cdo
 Arrangements: 1 Form C

The following diagram shows the location where the relays are wired to the connector #2 is wire

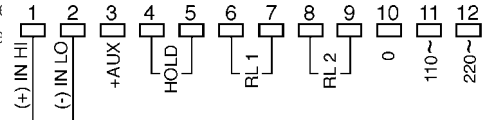

Normally closed contacts:

Programmed Values		When Above Set Point		When Below Set Point	
Alarm	Relay	Alarm	Relay	Alarm	Relay
UP	NE	On	Closed	Off	Open
UP	ND	On	Open	Off	Closed
DOWN	NE	Off	Open	On	Closed
DOWN	ND	Off	Closed	On	Open

NEMA 4 Cover

An optional NEMA 4 cover is available for use with all Hawk series controllers. This cover will help protect the controller in wash-down environments where water and dust are present. The cover has two gaskets and is mounted on the panel where the meter will be mounted.

This cover can be removed from the panel, exposing the meter front, by using the two screws on the left and right of the cover. When the bezel of the Hawk is exposed, the programming buttons can be accessed. This allows quick display scaling and decimal point selection without having to remove the meter from the panel.

Catalog # 45003

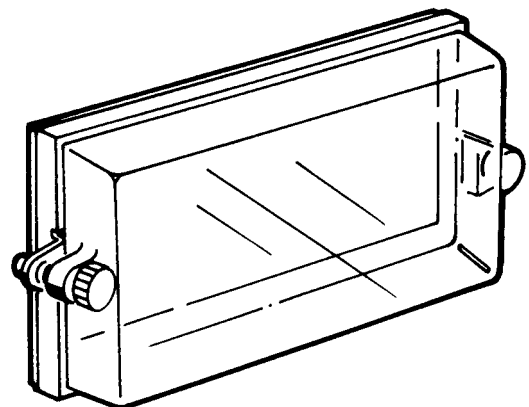

Application Example

A design engineer needs a controller that will display 100 feet-per-minute when a 20AC volt signal is applied. This signal is coming from a conveyor belt motor, which generates a linear speed output of 20 volts at 100 feet-per-minute. In addition, a relay is needed to trigger a rotating light if the displayed speed falls below 10 (FpM). Finally, a 0-10V output signal is needed. This will go to a chart recorder, which will mark a reading every five minutes.

A 3-1/2 digit Hawk 20AC Volt controller meets the application requirements. The display can be scaled to display feet-per-minute through the programming sequence. The HiE is set at 19.99, and the Hi is set at 100.0. The LoE and Lo are set at 0. When a signal is applied the meter will display 0-100.0 FpM.

A relay can be set to activate when the signal falls below 10 FpM. By specifying the set point at 10.0 in the programming sequence, and setting the alarm status as "dO," the relay will activate when the display falls below 10.0 FpM.

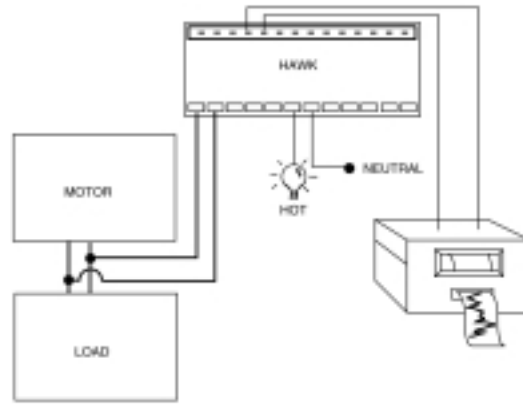

Hysteresis should be set at 1, requiring the input signal to rise 1% above the set point value before the relay is de-activated. This helps eliminate "chatter" in the relay. Also, the time delay should be set at 0. The relay can be wired to the light circuitry, and should be set up for normally energized.

The 0-10 V signal can be wired to the chart recorder. This signal also works in a linear progression, increasing the voltage from 0-10 as the display rises from 0-100. Pins 7A (over-range) and 9A (underrange) can be connected to warning lights, alerting the operator when and over/underrange situation occurs. In this state, a 5 VDC signal is available. Otherwise, the signal is 0 VDC (typical values).

Ordering Information

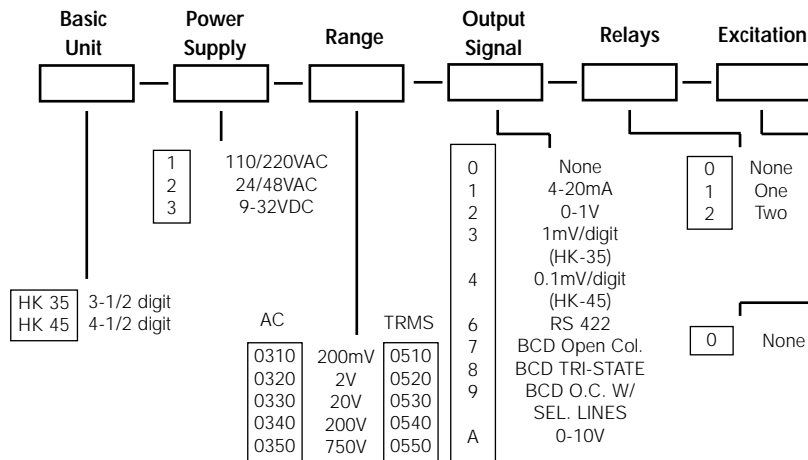

Safety Symbols

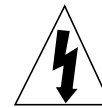

The WARNING sign denotes a hazard. It calls attention to a procedure, practice, or the like, which, if not correctly performed or adhered to, could result in personal injury.



The CAUTION sign denotes a hazard. It calls attention to an operating procedure, practice, or the like, which, if not correctly adhered to, could result in damage to or destruction of part or all of the instrument.

Accessories

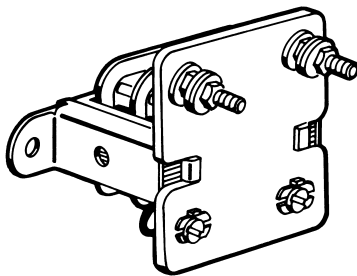

Model 186 Current Transformers easily convert a current signal (up to 50 amps) into a 0-10 AC volt signal and transmit the signal over a long distance. This allows remote monitoring of a process or application.

These transformers can be coupled with a Donut Current Transformer if a high current rating (up to 1999 amps) is to be monitored at a remote location.

Additional information can be found in the Accessory section of the Engineering Application Guide.

Ordering Information

Range	VA	Cat. Number
0-50mA	0.40	01294
0-100mA	0.50	01295
0-200mA	0.37	01296
0-300mA	0.48	01303
0-500mA	0.53	01304
0-750mA	0.37	01305
0-1amp	0.42	01308
0-2amp	0.54	01309
0-3amp	0.66	01311
0-5amp	0.75	01312
0-10amp	1.45	01314
0-15amp	1.05	01315
0-20amp	1.04	01316
0-25amp	1.50	01317
0-30amp	1.10	01318
0-40amp	1.09	01319
0-50amp	1.90	01321